



CN 212799482 U

2021.03.26

---

202021285947.9

2020.07.05

265500

16

(2006.01)

(2006.01)

(2006.01)

(2006.01)

(2006.01)

书1

书3

3

---

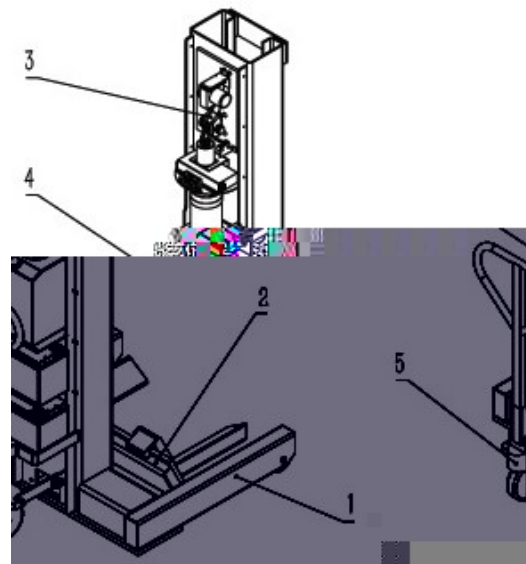

1.

2. 1  
" L" Q345B

3. 1

4. 1

5. 1

6. 1

7. 1

8. 7

Zi gBee

>

1

>

>



" 4 4  
2 8 2 10  
8 10 1 3  
9 9 7  
" "  
2 8 3 7  
" " 4 4  
2 8 3 4  
7 " " 8  
4 2 8  
10 1 2 10 9 8 9  
2 330  
7 " " 2  
2 6

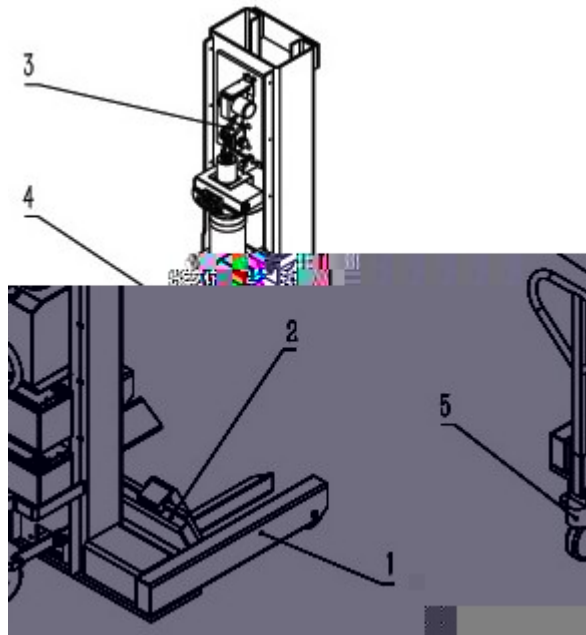

1

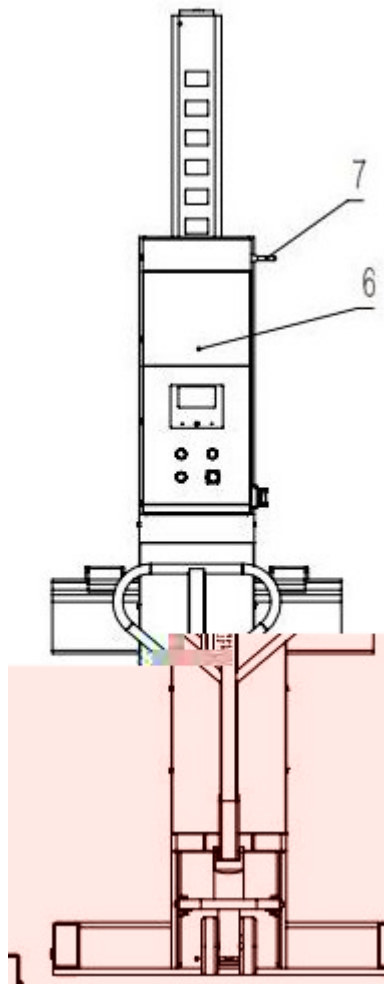

2

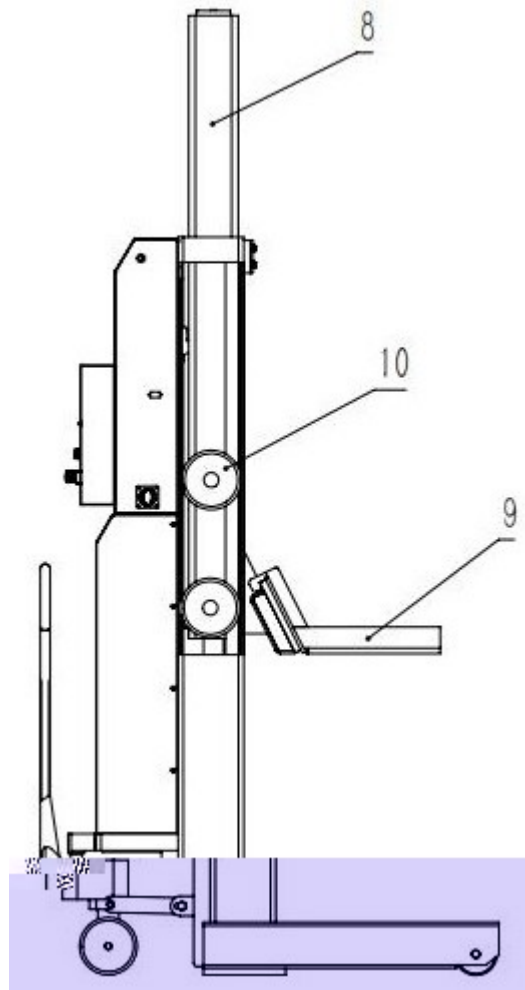

3